



THE PAPUA NEW GUINEA UNIVERSITY OF TECHNOLOGY
DEPARTMENT OF CIVIL ENGINEERING -2nd YEAR DEGREE
FIRST SEMESTER EXAMINATIONS - 2023
CE 211 – INTRODUCTION TO STRUCTURES

DATE: MONDAY, 5TH JUNE 2023 – 08:20 A.M

VENUE: STRUCTURES LECTURE THEATRE (SLT)

TIME ALLOWED: 3 HOURS

INFORMATION FOR CANDIDATES

1. You have 10 minutes to read the paper before the examination starts. You must **not** begin writing during this time.
2. **There are SEVEN (7) Questions in this paper. Answer any FIVE (5) questions which shall give a total of 50 points.**
3. Use only ink. Do not use pencils for writing except for drawings and sketches.
4. Only Calculator is allowed in the examination room. MOBILE PHONE is not allowed (**Switch your Mobile Phones OFF**). Notes and textbooks are not allowed.
5. Start each question on a new page and show all your calculations in the answer book provided. No other material will be accepted.
6. **Write your NAME and Student NUMBER clearly on the front page.**
Do it now.
7. **Marking Scheme:** All questions carry equal marks.

Question One

[Internal Member Forces]

(10 marks)

- a) Discuss the Method of Joints and the Method of Sections and state their advantages or disadvantages in determining internal member forces of a truss or frame. (2 Marks)
- b) Using the method of sections, write the equations and plot the shear force and bending moment diagrams for the cantilever beam shown in **Figure Q1B**. Indicate the salient values. (4 Marks)

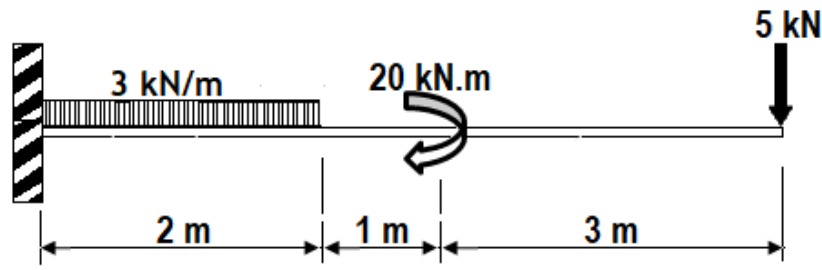
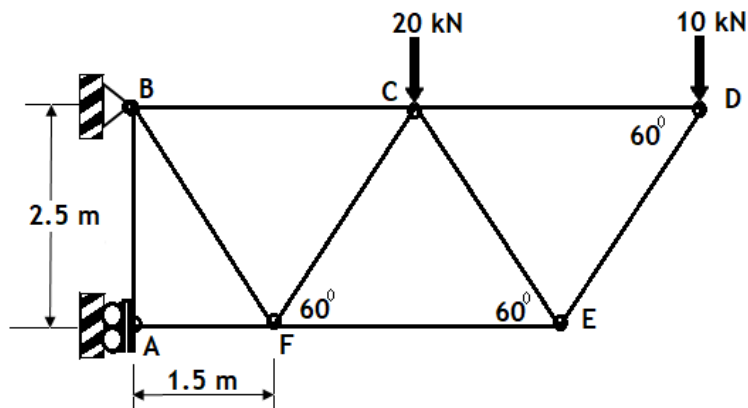

Figure Q1B

- c) Find the forces in the members **BC**, **CF**, and **CE** in the pin-jointed plane frame shown in **ABCDEF** shown in **Figure Q1C** and state the nature of the forces. Loads and dimensions are given in the diagram. (4 Marks)



- Notes: 1. Roller Support @A, Pinned Support @B
2. All members are 2 m long except as shown

Figure Q1C

Question Two [Space Frame: Tension Coefficient Method] (10 marks)

Determine the forces in the pin-jointed tripod cantilever bracket shown in **Figure Q2**.

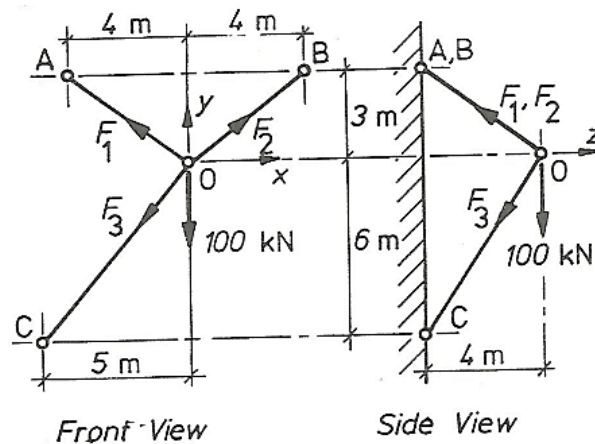

Figure Q2

Question Three [Three-pinned Arch] (10 marks)

- a) What is the difference between a two-pinned arch and a three-pinned arch? (2 marks)
- b) A **three-hinged** parabolic arch hinged at the supports and at the crown has a span of **24 m** and a central rise of **4 m**. It carries a concentrated load of **50 kN** at **18 m** from the left support and a uniformly distributed load of intensity **30 kN/m** over the entire span as shown in **Figure Q3**. Find the support reactions at the abutments/supports **A** and **B**, and the bending moments at the point load **D** and **E** (point load). Also draw the bending moment diagram for the arch (drawing not to scale). (8 marks)

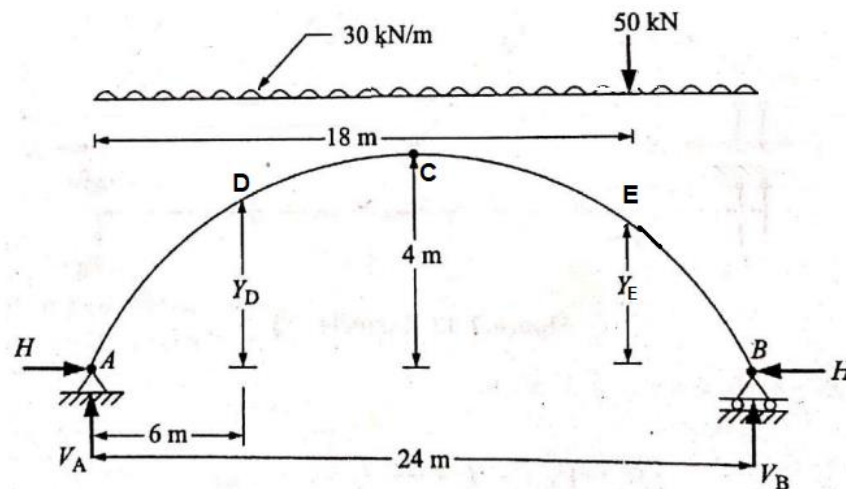

Figure Q3

Question Four

[Singularity Functions]

(10 marks)

- (a) Briefly discuss what singularity functions are and state why it is necessary for solving beam loadings. (3 Marks)
- (b) Using Singularity Functions, express the shear forces and bending moment in the beam shown in **Figure Q4**, and draw the shear force and bending moment diagrams for the beam and indicate principal values. Loads and dimensions are indicated in the diagram. (7 Marks)

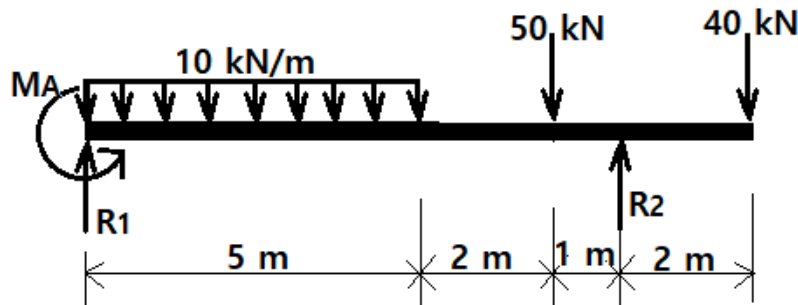

Figure Q4

Question Five

[Torsion of Solid/Hallow Shafts]

(10marks)

- (a) A hallow shaft has to transmit **6 MW at 150 rev/min**. The maximum allowable stress is not to exceed **60 MN/m²** not the angle of twist **0.3 °** per meter length of shafting. If the outside diameter of the shaft is **300 mm** find the minimum thickness of the hallow shaft to satisfy the above conditions. **G = 80 GN/m²**. (4 Marks)
- (b) A steel shaft **3 m** long is transmitting **1 MW at 240 rev/min**. The working conditions to be satisfied by the shaft are: (6 Marks)
1. That the shaft must not twist more than **0.02 radian on a length of 10 diameters**;
 2. That the working stress must not exceed **60 MN/m²**.
- If the modulus of rigidity of steel is **80 GN/m²** what is
- (i) The diameter of the shaft required;
 - (ii) The actual working stress;
 - (iii) The angle of twist of the **3 m** length?

Question Six [Bending & Shear Stress Distribution in Beams] (10 marks)

- (a) A uniform T-section beam is **150 mm** wide and **200 mm** deep as shown in **Figure Q6A**. If the limiting bending stresses for the material of the beam are **80 N/mm²** in compression and **160 MN/m²** in tension, find the maximum uniformly distributed load (udl) **w**, that the simply supported beam can carry over a length of **4 m**.
(3 Marks)

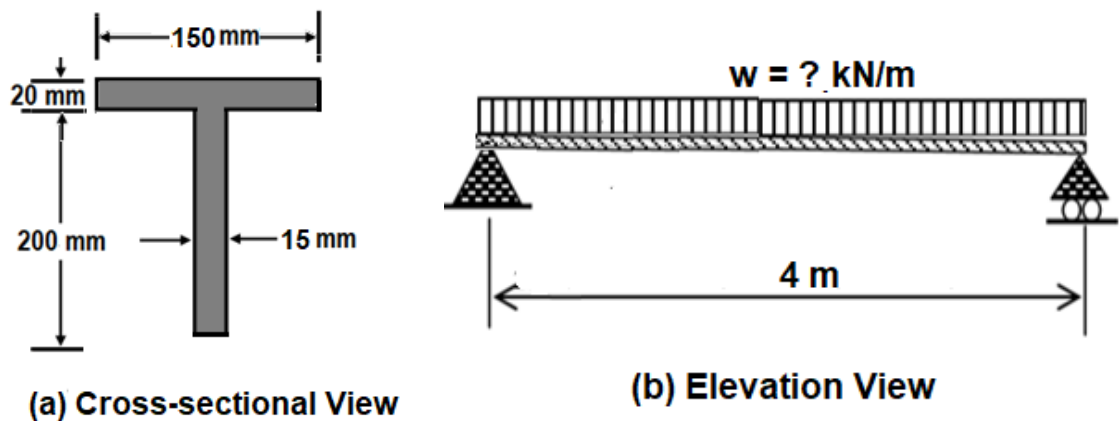
**Figure Q6A**

- (b) After determining the UDL **w**, plot the Shear Force and Bending Moment Diagrams for the simply supported beam in **Q6a**.
(2 Marks)
- (c) A steel girder beam has a uniform I-section (Figure Q) is subjected to a shear force of **250 kN** at a given position on the beam. Plot a curve to show the variation of shear stress distribution across the section and hence determine the ration of the maximum shear stress to the mean shear stress.
(5 Marks)

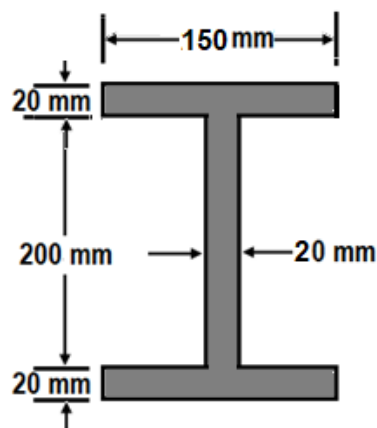
**Figure Q6C**

Question Seven

[Composite Beam Sections]

(10 marks)

- (a) State one reasons why a composite beam section may be necessary in design. (1 Marks)
- (b) A composite beam consists of a **400 mm x 250mm** timber joist strengthened by the addition of two steel plates **190 mm x 13 mm**, as shown in **Figure Q7B**. The safe stress in the timber is **6.5 N/mm²**, the safe stress in the steel is **175 N/mm²** and modular ration, **n =20**.
- Calculate the moment of resistance in **N.mm** (3 Marks)
 - If stress in the steel must not exceed **150 N/mm²** and the stress in the timber must **not exceed 8 N/mm²**, calculate the safe uniformly distributed load in **kN/m** on a span of **5 meters**. (2 Marks)

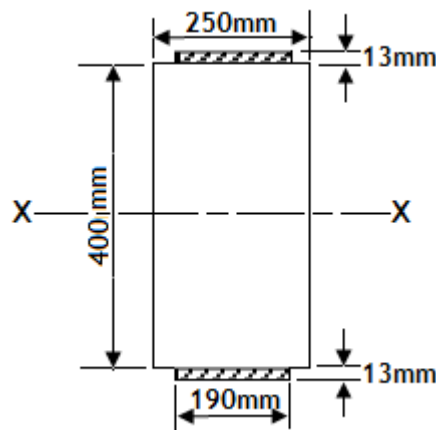

Figure Q7B

- (c) A timber beam is reinforced by a Steel plate as shown in **Figure Q7C**. Transform the two materials into a timber beam section and calculate the maximum stresses in the two materials for a bending moment of **15 kN.m**, and plot the stress (bending) distribution. Note: Modular Ration, **$E_s/E_T = 10$** . (4 Marks)

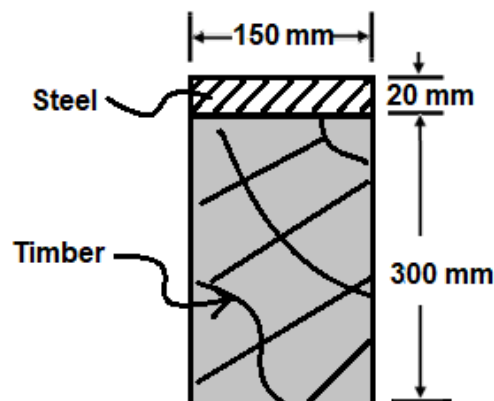

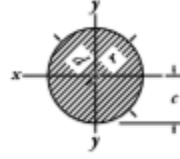
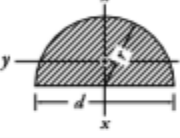
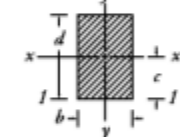
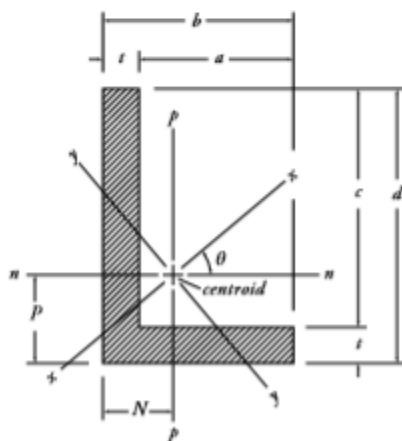

Figure Q7C

END OF EXAMINATION!!!! ALL THE BEST!!!!!!

Useful Properties of Areas

Section	Area	Centroidal distance c	Second moment of inertia		Elastic section modulus		
			I_x, I_y	I_y	Z_x	Z_y	r_x
	$\frac{bh}{2}$	$\frac{h}{3}$	$I_x = \frac{bh^3}{36}$	$\frac{hb^3}{48}$	Apex $\frac{bh^2}{24}$	$\frac{bh^2}{24}$	$4.24h$
			$I_y = \frac{bh^3}{12}$		Base $\frac{bh^2}{12}$		
	$3.14r^2$ $(= 0.785d^2)$	$r (= \frac{d}{2})$	$0.785r^4$ $(= 0.0491d^4)$	$0.785r^4$	$0.785r^3$ $(= 0.0982d^3)$	$0.785r^3$	$0.5r$ $(= 0.25d)$
	$1.57r^2$	$0.424r$	$0.393r^4$	$0.110r^4$	$0.393r^3$	Crown $0.191r^3$	$0.264r$
						Base $0.259r^3$	
	bd	$\frac{d}{2}$	$I_x = \frac{bd^3}{12}$	$\frac{db^3}{12}$	$\frac{bd^2}{6}$	$\frac{db^2}{6}$	$0.289d$
			$I_y = \frac{bd^3}{3}$				



$$\tan 2\theta = -\frac{2I_{np}}{I_n - I_p} \quad A = t(b+c)$$

$$N = \frac{b^2 + ct}{2(b+c)} \quad p = \frac{d^2 + at}{2(b+c)}$$

$$I_{np} = \pm \frac{abcdt}{4(b+c)}$$

$$I_n = \frac{1}{3} [t(d-p)^2 + bP^2 - a(p-t)^2]$$

$$I_p = \frac{1}{3} [t(b-N)^2 + dN^2 - c(N-t)^2]$$

$$I_x = \frac{I_n + I_p}{2} + \frac{I_n - I_p}{2\cos 2\theta}$$

$$I_y = \frac{I_n + I_p}{2} - \frac{I_n - I_p}{2\cos 2\theta}$$

x - and y -axis are the major and minor principal axis respectively (with $I_{xy} = 0$). Minimum $I = I_y$. The product second moment of inertia about the n -, p -axis (I_{np}) is -ve when the heel of the angle (with respect to the centroid) is in the 1st (top right) or 3rd (bottom left) quadrants and positive otherwise.

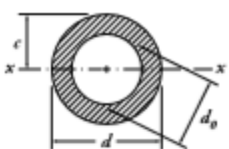
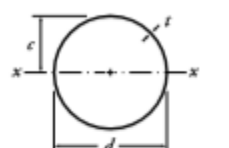
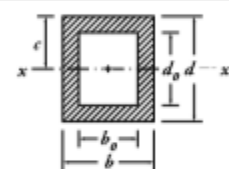
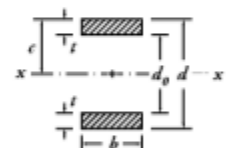
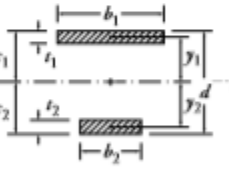
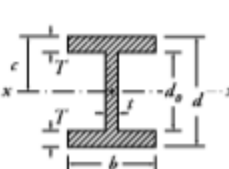
Section	Area A and Centroidal dist.	Second moment of area	Radius of gyration	Elastic section modulus
	A, c	I_x	r_x	Z_x
	$A = \frac{\pi}{4}(d^2 - d_0^2)$ $c = \frac{d}{2}$	$I_x = \frac{\pi}{64}(d^4 - d_0^4)$	$r_x = \frac{1}{4}\sqrt{d^2 + d_0^2}$	$Z = \frac{\pi}{32d}(d^4 - d_0^4)$
	$A = \pi(d-t)t$ $c = \frac{d}{2}$	$I_x = \frac{\pi}{8}(d-t)^3t$ $= 0.393(d-t)^3t$	$r_x \approx 0.354d$	$Z = \frac{\pi}{4} \frac{(d-t)^3t}{d}$
	$A = bd - b_0d_0$ $c = \frac{d}{2}$	$I_x = \frac{1}{12}(bd^3 - b_0d_0^3)$	$r_x = \sqrt{\frac{I_x}{A}}$	$Z_x = \frac{1}{6d}(bd^3 - b_0d_0^3)$
	$A = 2bt$ $c = \frac{d}{2}$	$I_x = \frac{b}{12}(d^3 - d_0^3)$	$r_x = \sqrt{\frac{I_x}{A}}$	$Z_x = \frac{b}{6d}(d^3 - d_0^3)$
	$A = b_1t_1 + b_2t_2$ $c_1 = \frac{\frac{1}{2}b_1t_1^2 + b_2t_2(d - \frac{1}{2}t_2)}{A}$		$r_x = \sqrt{\frac{I_x}{A}}$	$Z_{top} = \frac{I_x}{c_1}$
	$y_1 = \left(\frac{c_1 - t_1}{2}\right)$ $y_2 = \left(\frac{c_2 - t_2}{2}\right)$	$c_2 = d - c_1$ $I_x = \frac{b_1t_1^3}{12} + \frac{b_2t_2^3}{12} + b_1t_1y_1^2 + b_2t_2y_2^2$		$Z_{bot} = \frac{I_x}{c_2}$
	$A = 2bT + (d - 2T)t$ $c = \frac{d}{2}$	$d_0 = d - 2T$ $I_x = \frac{b}{12}(d^3 - d_0^3) + \frac{1}{12}d_0^3t$	$r_x = \sqrt{\frac{I_x}{A}}$	$Z_x = \frac{I_x}{c}$

Torsion Formulas

For a *solid or hollow shaft* of uniform circular cross-section throughout its length, the theory of pure torsion states that

$$\frac{T}{J} = \frac{\tau}{R} = \frac{G\theta}{L}$$

where T is the applied external torque, constant over length L ;

J is the polar second moment of area of shaft cross-section

$$= \frac{\pi D^4}{32} \text{ for a solid shaft and } \frac{\pi(D^4 - d^4)}{32} \text{ for a hollow shaft;}$$

D is the outside diameter; R is the outside radius;

d is the inside diameter;

τ is the shear stress at radius R and is the maximum value for both solid and hollow shafts;

G is the modulus of rigidity (shear modulus); and

θ is the angle of twist in *radians* on a length L .

For *very thin-walled hollow shafts*

$J = 2\pi r^3 t$, where r is the mean radius of the shaft wall and t is the thickness.

Shear stress and shear strain are related to the angle of twist thus:

$$\tau = \frac{G\theta}{L} R = G\gamma$$

Strain energy in torsion is given by

$$U = \frac{T^2 L}{2GJ} = \frac{GJ\theta^2}{2L}$$

For *solid shafts*

$$U = \frac{\tau^2}{4G} \times \text{volume}$$

For a circular shaft subjected to *combined bending and torsion* the *equivalent bending moment* is

$$M_e = \frac{1}{2}[M + \sqrt{(M^2 + T^2)}]$$

and the *equivalent torque* is

$$T_e = \frac{1}{2}\sqrt{(M^2 + T^2)}$$

where M and T are the applied bending moment and torque respectively.

Polar Second Moment Area

For a solid shaft,

$$J = 2\pi \left[\frac{r^4}{4} \right]_0^R$$

$$= \frac{2\pi R^4}{4} \quad \text{or} \quad \frac{\pi D^4}{32}$$

For a hollow shaft of internal radius r ,

$$J = 2\pi \int_r^R r^3 dr = 2\pi \left[\frac{r^4}{4} \right]_r^R$$

$$= \frac{\pi}{2} (R^4 - r^4) \quad \text{or} \quad \frac{\pi}{32} (D^4 - d^4)$$

For thin-walled hollow shafts the values of D and d may be nearly equal, and in such cases there can be considerable errors in using the above equation involving the difference of two large quantities of similar value. It is therefore convenient to obtain an alternative form of expression for the polar moment of area.

Now

$$J = \int_0^R 2\pi r^3 dr = \Sigma (2\pi r dr) r^2$$

$$= \Sigma A r^2$$

where $A (= 2\pi r dr)$ is the area of each small element of Fig. 8.3, i.e. J is the sum of the $A r^2$ terms for all elements.

If a thin hollow cylinder is therefore considered as just one of these small elements with its wall thickness $t = dr$, then

$$J = A r^2 = (2\pi r t) r^2$$

$$= 2\pi r^3 t \quad (\text{approximately})$$

Composite Shaft – Parallel Connections

If two or more materials are rigidly fixed together such that the applied torque is shared between them then the composite shaft so formed is said to be *connected in parallel* (Fig. 8.6).

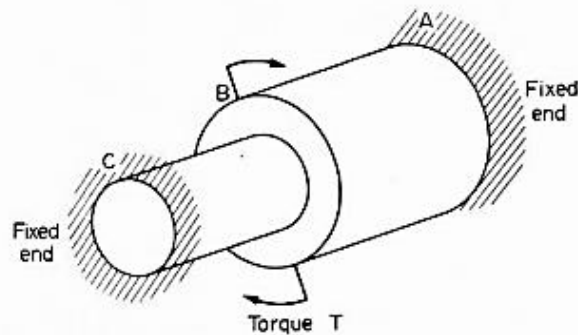

Fig. 8.6. "Parallel-connected" shaft – shared torque.

For parallel connection,

$$\text{total torque } T = T_1 + T_2$$

In this case the angles of twist of each portion are equal and

$$\frac{T_1 L_1}{G_1 J_1} = \frac{T_2 L_2}{G_2 J_2}$$

i.e. for equal lengths (as is normally the case for parallel shafts)

$$\frac{T_1}{T_2} = \frac{G_1 J_1}{G_2 J_2}$$

Thus two equations are obtained in terms of the torques in each part of the composite shaft and these torques can therefore be determined.

The maximum stresses in each part can then be found from

$$\tau_1 = \frac{T_1 R_1}{J_1} \quad \text{and} \quad \tau_2 = \frac{T_2 R_2}{J_2}$$

Shear Stress Distribution Formulas

Summary

The *shear stress* in a beam at any transverse cross-section in its length, and at a point a vertical distance y from the neutral axis, *resulting from bending* is given by

$$\tau = \frac{QA\bar{y}}{Ib} \quad \text{or} \quad \tau = \frac{Q}{Ib} \int ydA$$

where Q is the applied vertical shear force at that section; A is the area of cross-section "above" y , i.e. the area between y and the outside of the section, which may be above or below the neutral axis (N.A.); \bar{y} is the distance of the centroid of area A from the N.A.; I is the second moment of area of the complete cross-section; and b is the breadth of the section at position y .

For rectangular sections,

$$\tau = \frac{6Q}{bd^3} \left[\frac{d^2}{4} - y^2 \right] \quad \text{with} \quad \tau_{\max} = \frac{3Q}{2bd} \quad \text{when} \quad y = 0$$

For I-section beams the *vertical shear* in the web is given by

$$\tau = \frac{Q}{2I} \left[\frac{h^2}{4} - y^2 \right] + \frac{Qb}{2It} \left[\frac{d^2}{4} - \frac{h^2}{4} \right]$$

with a *maximum* value of

$$\tau_{\max} = \frac{Qh^2}{8I} + \frac{Qb}{2It} \left[\frac{d^2}{4} - \frac{h^2}{4} \right]$$

The *maximum* value of the *horizontal shear* in the flanges is

$$\tau_{\max} = \frac{Qb}{4I} (d - t_1)$$

For **circular** sections

$$\tau = \frac{4Q}{3\pi R^2} \left[1 - \left(\frac{y}{R} \right)^2 \right]$$

with a *maximum* value of

$$\tau_{\max} = \frac{4Q}{3\pi R^2}$$

The *shear centre* of a section is that point, in or outside the section, through which load must be applied to produce zero twist of the section. Should a section have two axes of symmetry, the point where they cross is automatically the shear centre.

The shear centre of a **channel** section is given by

$$e = \frac{k^2 h^2 t}{4I}$$

$$\tau_{\max} = \frac{Qb}{4I} (d - t_1) \quad \text{at the centre}$$