

THE PAPUA NEW GUINEA UNIVERSITY OF TECHNOLOGY

EXAMINATIONS

SEMESTER II-2024

ME221 THERMAL POWER & SYSTEMS

MONDAY, 21 OCTOBER 2023 [8:30AM-10:00 AM]

TIME ALLOWED: 2.5 HOURS

**INSTRUCTIONS:**

1. You have 10 minutes to read the paper. You must not begin writing this time.
2. There are 04 questions, and attempt all questions.
3. Start each question on a new page and show all your calculations in the answer book provided. No other written will be accepted.
4. Write down your full name and student number clearly on the front page. **Do it now.**
5. Calculator is permitted in the examination room. Notes, textbooks or phones are not allowed.
6. **Any candidate cheating the examinations will be disqualified.**
7. Assume data if missing any and make use of proper unites for calculations where needed.
8. Steam and air properties tables are attached at end of this question paper.

Question No.	Topics	Marks
1	Conventional thermal power plants	20
2	Air pollution caused by burning of fossil fuels	3
3	Renewable energy technologies	12
4	Geothermal power plant	5
<b>Total Marks</b>		<b>40</b>

**Question # 1****Marks 20 = 2 + 4 + 5 + 4 + 5**

For a combined gas–steam power cycle shown in Figure 1, the gas turbine cycle (topping cycle) operates with the following parameters:

- Air enters the compressor at 25 C° and is compressed to 230 C°.
- After compression, the temperature of the compressed air is raised to 970 C° by combustion in the combustion chamber before entering the gas turbine.
- Exhaust gases leave the turbine at 480 C° and are passed to a Heat Recovery Steam Generator (HRSG), where they transfer heat to water. The exhaust gases leaving the HRSG are at 180 C°.

And, the Rankine cycle (bottoming cycle) operates with the following parameters:

- Steam is generated in the HRSG at a pressure of 6 MPa and a temperature of 600 C° before entering the steam turbine.
- The exhaust steam from the turbine is saturated vapor (dryness fraction = 1) at 10 kPa.

You should:

- a) Construct a TS diagram for the combined power plant, including both the gas turbine (topping) and steam turbine (bottoming) cycles. Clearly label each process on the diagram.
- b) Calculate the thermodynamic states of the working fluids (water and gas) by determining the specific enthalpy across each equipment within the combined power plant.
- c) Compare the back-work ratios of the gas turbine cycle with that of the steam turbine cycle, and discuss it.
- d) Compare the thermal efficiencies of both gas and steam power plants.
- e) Compute the overall efficiency of the combined gas-steam power plant, and discuss the potential pros and cons of combining these cycles.

**Tips:**

- *Back work ratio: The fraction of the turbine work used to drive the compressor or pump in power plant*
- *For temperature conversion, use  $K = C^{\circ} + 273$ .*
- *Thermodynamic Efficiency =  $\frac{W_{net}}{Q_{in}} = 1 - \frac{Q_{out}}{Q_{in}}$ , where:  $Q_{in} = W_{net} + Q_{out}$*

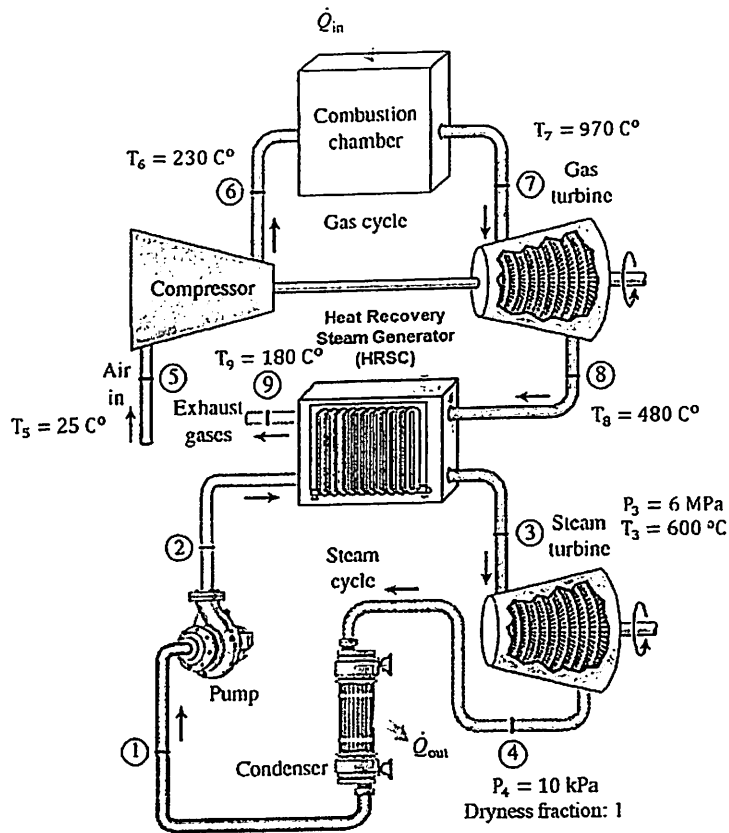

Figure 1. Schematic of the combined gas-steam power plant.

**Question # 2**

**Marks 3 = 1 + 1 + 1**

Combustion of fossil fuels (coal, diesel, and natural gas) in thermal power plants is a major cause of air pollution. Briefly discuss how the air pollutants from the fuel combustion contribute to global warming, acid rain, and smog?

**Question # 3**

**Marks 12 = 4 + 4 + 4**

Briefly discuss any three of the following electricity generation technologies:

- Run-of-river hydroelectric power plant
- Oscillating water column wave energy converter
- High-temperature solar thermal energy generator
- Vertical axis wind turbine (VAWT)
- Pressurized water reactor (PWR) nuclear power plant.

In your discussion, describe the working principles with schematic diagram, key features and limitations of each technology.

**Question # 4**

**Marks = 5**

A geothermal resource (using flash chamber and separator equipment as shown in Figure 2) generates saturated steam at  $250\text{ }^{\circ}\text{C}$  at a flow rate of  $230\text{ kg/s}$ , which is fed to a steam turbine for electricity generation. The steam leaves the turbine at  $10\text{ kPa}$  with a moisture content of 5 percent. Compute the power generated from the steam turbine.

*(Tip: First, determine the specific enthalpy of steam entering and exiting the turbine, then calculate power by multiplying the mass flow rate by the change in specific enthalpy.)*

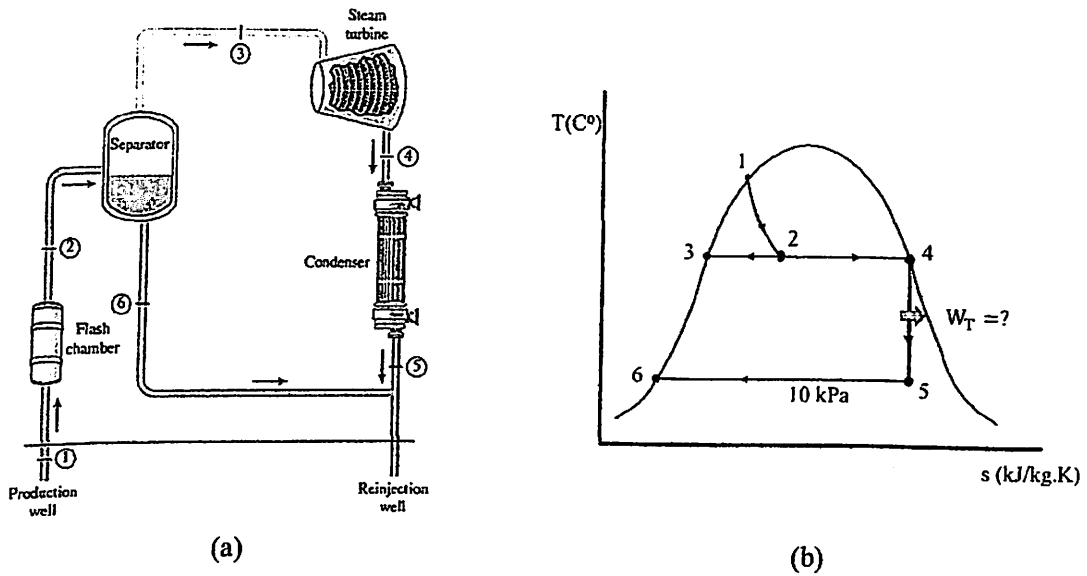

Figure 2. (a) Schematic of geothermal steam power plant, and (b) corresponding TS-diagram.

### Air Properties Table

824

PROPERTY TABLES AND CHARTS

**TABLE A-17**

Ideal-gas properties of air

$T$ K	$h$ kJ/kg	$P_r$	$u$ kJ/kg	$v_r$	$s^\circ$ kJ/kg-K	$T$ K	$h$ kJ/kg	$P_r$	$u$ kJ/kg	$v_r$	$s^\circ$ kJ/kg-K
200	199.97	0.3363	142.56	1707.0	1.29559	580	586.04	14.38	419.55	115.7	2.37348
210	209.97	0.3987	149.69	1512.0	1.34444	590	596.52	15.31	427.15	110.6	2.39140
220	219.97	0.4690	156.82	1346.0	1.39105	600	607.02	16.28	434.78	105.8	2.40902
230	230.02	0.5477	164.00	1205.0	1.43557	610	617.53	17.30	442.42	101.2	2.42644
240	240.02	0.6355	171.13	1084.0	1.47824	620	628.07	18.36	450.09	96.92	2.44356
250	250.05	0.7329	178.28	979.0	1.51917	630	638.63	19.84	457.78	92.84	2.46048
260	260.09	0.8405	185.45	887.8	1.55848	640	649.22	20.64	465.50	88.99	2.47716
270	270.11	0.9590	192.60	808.0	1.59634	650	659.84	21.86	473.25	85.34	2.49364
280	280.13	1.0889	199.75	738.0	1.63279	660	670.47	23.13	481.01	81.89	2.50985
285	285.14	1.1584	203.33	706.1	1.65055	670	681.14	24.46	488.81	78.61	2.52589
290	290.16	1.2311	206.91	676.1	1.66802	680	691.82	25.85	496.62	75.50	2.54175
295	295.17	1.3068	210.49	647.9	1.68515	690	702.52	27.29	504.45	72.56	2.55731
298	298.18	1.3543	212.64	631.9	1.69528	700	713.27	28.80	512.33	69.76	2.57277
300	300.19	1.3860	214.07	621.2	1.70203	710	724.04	30.38	520.23	67.07	2.58810
305	305.22	1.4686	217.67	596.0	1.71865	720	734.82	32.02	528.14	64.53	2.60319
310	310.24	1.5546	221.25	572.3	1.73498	730	745.62	33.72	536.07	62.13	2.61803
315	315.27	1.6442	224.85	549.8	1.75106	740	756.44	35.50	544.02	59.82	2.63280
320	320.29	1.7375	228.42	528.6	1.76690	750	767.29	37.35	551.99	57.63	2.64737
325	325.31	1.8345	232.02	508.4	1.78249	760	778.18	39.27	560.01	55.54	2.66176
330	330.34	1.9352	235.61	489.4	1.79783	780	800.03	43.35	576.12	51.64	2.69013
340	340.42	2.149	242.82	454.1	1.82790	800	821.95	47.75	592.30	48.08	2.71787
350	350.49	2.379	250.02	422.2	1.85708	820	843.98	52.59	608.59	44.84	2.74504
360	360.58	2.626	257.24	393.4	1.88543	840	866.08	57.60	624.95	41.85	2.77170
370	370.67	2.892	264.46	367.2	1.91313	860	888.27	63.09	641.40	39.12	2.79783
380	380.77	3.176	271.69	343.4	1.94001	880	910.56	68.98	657.95	36.61	2.82344
390	390.88	3.481	278.93	321.5	1.96633	900	932.93	75.29	674.58	34.31	2.84856
400	400.98	3.806	286.16	301.6	1.99194	920	955.38	82.05	691.28	32.18	2.87324
410	411.12	4.153	293.43	283.3	2.01699	940	977.92	89.28	708.08	30.22	2.89748
420	421.26	4.522	300.69	266.6	2.04142	960	1000.55	97.00	725.02	28.40	2.92128
430	431.43	4.915	307.99	251.1	2.06533	980	1023.25	105.2	741.98	26.73	2.94468
440	441.61	5.332	315.30	236.8	2.08870	1000	1046.04	114.0	758.94	25.17	2.96770
450	451.80	5.775	322.62	223.6	2.11161	1020	1068.89	123.4	776.10	23.72	2.99034
460	462.02	6.245	329.97	211.4	2.13407	1040	1091.85	133.3	793.36	22.29	3.01260
470	472.24	6.742	337.32	200.1	2.15604	1060	1114.86	143.9	810.62	21.14	3.03449
480	482.49	7.268	344.70	189.5	2.17760	1080	1137.89	155.2	827.88	19.98	3.05608
490	492.74	7.824	352.08	179.7	2.19876	1100	1161.07	167.1	845.33	18.896	3.07732
500	503.02	8.411	359.49	170.6	2.21952	1120	1184.28	179.7	862.79	17.886	3.09825
510	513.32	9.031	366.92	162.1	2.23993	1140	1207.57	193.1	880.35	16.946	3.11883
520	523.63	9.684	374.36	154.1	2.25997	1160	1230.92	207.2	897.91	16.064	3.13916
530	533.98	10.37	381.84	146.7	2.27967	1180	1254.34	222.2	915.57	15.241	3.15916
540	544.35	11.10	389.34	139.7	2.29906	1200	1277.79	238.0	933.33	14.470	3.17888
550	555.74	11.86	396.86	133.1	2.31809	1220	1301.31	254.7	951.09	13.747	3.19834
560	565.17	12.66	404.42	127.0	2.33685	1240	1324.93	272.3	968.95	13.069	3.21751
570	575.59	13.50	411.97	121.2	2.35531						

**TABLE A-17**

Ideal gas properties of air (Continued)

$T$ K	$h$ kJ/kg	$P_r$	$u$ kJ/kg	$v_r$	$s^\circ$ kJ/kg·K	$T$ K	$h$ kJ/kg	$P_r$	$u$ kJ/kg	$v_r$	$s^\circ$ kJ/kg·K
1260	1348.55	290.8	986.90	12.435	3.23638	1600	1757.57	791.2	1298.30	5.804	3.52364
1280	1372.24	310.4	1004.76	11.835	3.25510	1620	1782.00	834.1	1316.96	5.574	3.53879
1300	1395.97	330.9	1022.82	11.275	3.27345	1640	1806.46	878.9	1335.72	5.355	3.55381
1320	1419.76	352.5	1040.88	10.747	3.29160	1660	1830.95	925.6	1354.48	5.147	3.56867
1340	1443.60	375.3	1058.94	10.247	3.30959	1680	1855.50	974.2	1373.24	4.949	3.58335
1360	1467.49	399.1	1077.10	9.780	3.32724	1700	1880.1	1025	1392.7	4.761	3.5979
1380	1491.44	424.2	1095.26	9.337	3.34474	1750	1941.6	1161	1439.8	4.328	3.6336
1400	1515.42	450.5	1113.52	8.919	3.36200	1800	2003.3	1310	1487.2	3.994	3.6684
1420	1539.44	478.0	1131.77	8.526	3.37901	1850	2065.3	1475	1534.9	3.601	3.7023
1440	1563.51	506.9	1150.13	8.153	3.39586	1900	2127.4	1655	1582.6	3.295	3.7354
1460	1587.63	537.1	1168.49	7.801	3.41247	1950	2189.7	1852	1630.6	3.022	3.7677
1480	1611.79	568.8	1186.95	7.468	3.42892	2000	2252.1	2068	1678.7	2.776	3.7994
1500	1635.97	601.9	1205.41	7.152	3.44516	2050	2314.6	2303	1726.8	2.555	3.8303
1520	1660.23	636.5	1223.87	6.854	3.46120	2100	2377.7	2559	1775.3	2.356	3.8605
1540	1684.51	672.8	1242.43	6.569	3.47712	2150	2440.3	2837	1823.8	2.175	3.8901
1560	1708.82	710.5	1260.99	6.301	3.49276	2200	2503.2	3138	1872.4	2.012	3.9191
1580	1733.17	750.0	1279.65	6.046	3.50829	2250	2566.4	3464	1921.3	1.864	3.9474

Note: The properties  $P_r$  (relative pressure) and  $v_r$  (relative specific volume) are dimensionless quantities used in the analysis of isentropic processes, and should not be confused with the properties pressure and specific volume.

Source of Data: Kenneth Wark, *Thermodynamics*, 4th ed. (New York: McGraw-Hill, 1983), pp. 785–86, table A-5. Originally published in J. H. Keenan and J. Kaye, *Gas Tables* (New York: John Wiley & Sons, 1948).

## Steam Properties Table

### a. Saturated Water

Press., <i>P</i> kPa	Sat. temp., <i>T</i> <sub>sat</sub> °C	Specific volume, m <sup>3</sup> /kg		Internal energy, kJ/kg			Enthalpy, kJ/kg			Entropy, kJ/kg-K		
		Sat. liquid, <i>v</i> <sub>f</sub>	Sat. vapor, <i>v</i> <sub>g</sub>	Sat. liquid, <i>u</i> <sub>f</sub>	Evap., <i>u</i> <sub>fg</sub>	Sat. vapor, <i>u</i> <sub>g</sub>	Sat. liquid, <i>h</i> <sub>f</sub>	Evap., <i>h</i> <sub>fg</sub>	Sat. vapor, <i>h</i> <sub>g</sub>	Sat. liquid, <i>s</i> <sub>f</sub>	Evap., <i>s</i> <sub>fg</sub>	Sat. vapor, <i>s</i> <sub>g</sub>
1.0	6.97	0.001000	129.19	29.302	2355.2	2384.5	29.303	2484.4	2513.7	0.1059	8.8690	8.9749
1.5	13.02	0.001001	87.964	54.686	2338.1	2392.8	54.688	2470.1	2524.7	0.1956	8.6314	8.8270
2.0	17.50	0.001001	66.990	73.431	2325.5	2398.9	73.433	2459.5	2532.9	0.2606	8.4621	8.7227
2.5	21.08	0.001002	54.242	88.422	2315.4	2403.8	88.424	2451.0	2539.4	0.3118	8.3302	8.6421
3.0	24.08	0.001003	45.654	100.98	2306.9	2407.9	100.98	2443.9	2544.8	0.3543	8.2222	8.5765
4.0	28.96	0.001004	34.791	121.39	2293.1	2414.5	121.39	2432.3	2553.7	0.4224	8.0510	8.4734
5.0	32.87	0.001005	28.185	137.75	2282.1	2419.8	137.75	2423.0	2560.7	0.4762	7.9176	8.3938
7.5	40.29	0.001008	19.233	168.74	2261.1	2429.8	168.75	2405.3	2574.0	0.5763	7.6738	8.2501
10	45.81	0.001010	14.670	191.79	2245.4	2437.2	191.81	2392.1	2583.9	0.6492	7.4996	8.1488
15	53.97	0.001014	10.020	225.93	2222.1	2448.0	225.94	2372.3	2598.3	0.7549	7.2522	8.0071
20	60.06	0.001017	7.6481	251.40	2204.6	2456.0	251.42	2357.5	2608.9	0.8320	7.0752	7.9073
25	64.96	0.001020	6.2034	271.93	2190.4	2462.4	271.96	2345.5	2617.5	0.8932	6.9370	7.8302
30	69.09	0.001022	5.2287	289.24	2178.5	2467.7	289.27	2335.3	2624.6	0.9441	6.8234	7.7675
40	75.86	0.001026	3.9933	317.58	2158.8	2476.3	317.62	2318.4	2636.1	1.0261	6.6430	7.6691
50	81.32	0.001030	3.2403	340.49	2142.7	2483.2	340.54	2304.7	2645.2	1.0912	6.5019	7.5931
75	91.76	0.001037	2.2172	384.36	2111.8	2496.1	384.44	2278.0	2662.4	1.2132	6.2426	7.4558
100	99.61	0.001043	1.6941	417.40	2088.2	2505.6	417.51	2257.5	2675.0	1.3028	6.0562	7.3589
101.325	99.97	0.001043	1.6734	418.95	2087.0	2506.0	419.06	2256.5	2675.6	1.3069	6.0476	7.3545
125	105.97	0.001048	1.3750	444.23	2068.8	2513.0	444.36	2240.6	2684.9	1.3741	5.9100	7.2841
150	111.35	0.001053	1.1594	466.97	2052.3	2519.2	467.13	2226.0	2693.1	1.4337	5.7894	7.2231
175	116.04	0.001057	1.0037	486.82	2037.7	2524.5	487.01	2213.1	2700.2	1.4850	5.6865	7.1716
200	120.21	0.001061	0.88578	504.50	2024.6	2529.1	504.71	2201.6	2706.3	1.5302	5.5968	7.1270
225	123.97	0.001064	0.79329	520.47	2012.7	2533.2	520.71	2191.0	2711.7	1.5706	5.5171	7.0877
250	127.41	0.001067	0.71873	535.08	2001.8	2536.8	535.35	2181.2	2716.5	1.6072	5.4453	7.0525
275	130.58	0.001070	0.65732	548.57	1991.6	2540.1	548.86	2172.0	2720.9	1.6408	5.3800	7.0207
300	133.52	0.001073	0.60582	561.11	1982.1	2543.2	561.43	2163.5	2724.9	1.6717	5.3200	6.9917
325	136.27	0.001076	0.56199	572.84	1973.1	2545.9	573.19	2155.4	2728.6	1.7005	5.2645	6.9650
350	138.86	0.001079	0.52422	583.89	1964.6	2548.5	584.26	2147.7	2732.0	1.7274	5.2128	6.9402
375	141.30	0.001081	0.49133	594.32	1956.6	2550.9	594.73	2140.4	2735.1	1.7526	5.1645	6.9171
400	143.61	0.001084	0.46242	604.22	1948.9	2553.1	604.66	2133.4	2738.1	1.7765	5.1191	6.8955
450	147.90	0.001088	0.41392	622.65	1934.5	2557.1	623.14	2120.3	2743.4	1.8205	5.0356	6.8561
500	151.83	0.001093	0.37483	639.54	1921.2	2560.7	640.09	2108.0	2748.1	1.8604	4.9603	6.8207
550	155.46	0.001097	0.34261	655.16	1908.8	2563.9	655.77	2096.6	2752.4	1.8970	4.8916	6.7886
600	158.83	0.001101	0.31560	669.72	1897.1	2566.8	670.38	2085.8	2756.2	1.9308	4.8285	6.7593
650	161.98	0.001104	0.29260	683.37	1886.1	2569.4	684.08	2075.5	2759.6	1.9623	4.7699	6.7322
700	164.95	0.001108	0.27278	696.23	1875.6	2571.8	697.00	2065.8	2762.8	1.9918	4.7153	6.7071
750	167.75	0.001111	0.25552	708.40	1865.6	2574.0	709.24	2056.4	2765.7	2.0195	4.6642	6.6837

b. Superheated Water

T °C	v m <sup>3</sup> /kg	u kJ/kg	h kJ/kg	s kJ/kg·K	v m <sup>3</sup> /kg	u kJ/kg	h kJ/kg	s kJ/kg·K	v m <sup>3</sup> /kg	u kJ/kg	h kJ/kg	s kJ/kg·K			
				P = 1.00 MPa (179.88°C)				P = 1.20 MPa (187.96°C)				P = 1.40 MPa (195.04°C)			
Sat.	0.19437	2582.8	2777.1	6.5850	0.16326	2587.8	2783.8	6.5217	0.14078	2591.8	2788.9	6.4675			
200	0.20602	2622.3	2828.3	6.6956	0.16934	2612.9	2816.1	6.5909	0.14303	2602.7	2803.0	6.4975			
250	0.23275	2710.4	2943.1	6.9265	0.19241	2704.7	2935.6	6.8313	0.16356	2698.9	2927.9	6.7488			
300	0.25799	2793.7	3051.6	7.1246	0.21386	2789.7	3046.3	7.0335	0.18233	2785.7	3040.9	6.9553			
350	0.28250	2875.7	3158.2	7.3029	0.23455	2872.7	3154.2	7.2139	0.20029	2869.7	3150.1	7.1379			
400	0.30661	2957.9	3264.5	7.4670	0.25482	2955.5	3261.3	7.3793	0.21782	2953.1	3258.1	7.3046			
500	0.35411	3125.0	3479.1	7.7642	0.29464	3123.4	3477.0	7.6779	0.25216	3121.8	3474.8	7.6047			
600	0.40111	3297.5	3698.6	8.0311	0.33395	3296.3	3697.0	7.9456	0.28597	3295.1	3695.5	7.8730			
700	0.44783	3476.3	3924.1	8.2755	0.37297	3475.3	3922.9	8.1904	0.31951	3474.4	3921.7	8.1183			
800	0.49438	3661.7	4156.1	8.5024	0.41184	3661.0	4155.2	8.4176	0.35288	3660.3	4154.3	8.3458			
900	0.54083	3853.9	4394.8	8.7150	0.45059	3853.3	4394.0	8.6303	0.38614	3852.7	4393.3	8.5587			
1000	0.58721	4052.7	4640.0	8.9155	0.48928	4052.2	4639.4	8.8310	0.41933	4051.7	4638.8	8.7595			
1100	0.63354	4257.9	4891.4	9.1057	0.52792	4257.5	4891.0	9.0212	0.45247	4257.0	4890.5	8.9497			
1200	0.67983	4469.0	5148.9	9.2866	0.56652	4468.7	5148.5	9.2022	0.48558	4468.3	5148.1	9.1308			
1300	0.72610	4685.8	5411.9	9.4593	0.60509	4685.5	5411.6	9.3750	0.51866	4685.1	5411.3	9.3036			
				P = 1.60 MPa (201.37°C)				P = 1.80 MPa (207.11°C)				P = 2.00 MPa (212.38°C)			
Sat.	0.12374	2594.8	2792.8	6.4200	0.11037	2597.3	2795.9	6.3775	0.09959	2599.1	2798.3	6.3390			
225	0.13293	2645.1	2857.8	6.5537	0.11678	2637.0	2847.2	6.4825	0.10381	2628.5	2836.1	6.4160			
250	0.14190	2692.9	2919.9	6.6753	0.12502	2686.7	2911.7	6.6088	0.11150	2680.3	2903.3	6.5475			
300	0.15866	2781.6	3035.4	6.8864	0.14025	2777.4	3029.9	6.8246	0.12551	2773.2	3024.2	6.7684			
350	0.17459	2866.6	3146.0	7.0713	0.15460	2863.6	3141.9	7.0120	0.13860	2860.5	3137.7	6.9583			
400	0.19007	2950.8	3254.9	7.2394	0.16849	2948.3	3251.6	7.1814	0.15122	2945.9	3248.4	7.1292			
500	0.22029	3120.1	3472.6	7.5410	0.19551	3118.5	3470.4	7.4845	0.17568	3116.9	3468.3	7.4337			
600	0.24999	3293.9	3693.9	7.8101	0.22200	3292.7	3692.3	7.7543	0.19962	3291.5	3690.7	7.7043			
700	0.27941	3473.5	3920.5	8.0558	0.24822	3472.6	3919.4	8.0005	0.22326	3471.7	3918.2	7.9509			
800	0.30865	3659.5	4153.4	8.2834	0.27426	3658.8	4152.4	8.2284	0.24674	3658.0	4151.5	8.1791			
900	0.33780	3852.1	4392.6	8.4965	0.30020	3851.5	4391.9	8.4417	0.27012	3850.9	4391.1	8.3925			
1000	0.36687	4051.2	4638.2	8.6974	0.32606	4050.7	4637.6	8.6427	0.29342	4050.2	4637.1	8.5936			
1100	0.39589	4256.6	4890.0	8.8878	0.35188	4256.2	4889.6	8.8331	0.31667	4255.7	4889.1	8.7842			
1200	0.42488	4467.9	5147.7	9.0689	0.37766	4467.6	5147.3	9.0143	0.33989	4467.2	5147.0	8.9654			
1300	0.45383	4684.8	5410.9	9.2418	0.40341	4684.5	5410.6	9.1872	0.36308	4684.2	5410.3	9.1384			
				P = 2.50 MPa (223.95°C)				P = 3.00 MPa (233.85°C)				P = 3.50 MPa (242.56°C)			
Sat.	0.07995	2602.1	2801.9	6.2558	0.06667	2603.2	2803.2	6.1856	0.05706	2603.0	2802.7	6.1244			
225	0.08026	2604.8	2805.5	6.2629	0.07063	2644.7	2856.5	6.2893	0.05876	2624.0	2829.7	6.1764			
250	0.08705	2663.3	2880.9	6.4107	0.08118	2750.8	2994.3	6.5412	0.06845	2738.8	2978.4	6.4484			
300	0.09894	2762.2	3009.6	6.6459	0.09056	2844.4	3116.1	6.7450	0.07680	2836.0	3104.9	6.6601			
350	0.10979	2852.5	3127.0	6.8424	0.09938	2933.6	3231.7	6.9235	0.08456	2927.2	3223.2	6.8428			
400	0.12012	2939.8	3240.1	7.0170	0.10789	3021.2	3344.9	7.0856	0.09198	3016.1	3338.1	7.0074			
450	0.13015	3026.2	3351.6	7.1768	0.11620	3108.6	3457.2	7.2359	0.09919	3104.5	3451.7	7.1593			
500	0.13999	3112.8	3462.8	7.3254	0.13245	3285.5	3682.8	7.5103	0.11325	3282.5	3678.9	7.4357			
600	0.15931	3288.5	3686.8	7.5979	0.14841	3467.0	3912.2	7.7590	0.12702	3464.7	3909.3	7.6855			
700	0.17835	3469.3	3915.2	7.8455	0.16420	3654.3	4146.9	7.9885	0.14061	3652.5	4144.6	7.9156			
800	0.19722	3656.2	4149.2	8.0744	0.17988	3847.9	4387.5	8.2028	0.15410	3846.4	4385.7	8.1304			
900	0.21597	3849.4	4389.3	8.2882	0.19549	4047.7	4632.2	8.4045	0.16751	4046.4	4632.7	8.3324			
1000	0.23466	4049.0	4635.6	8.4897	0.21105	4253.6	4886.7	8.5955	0.18087	4252.5	4885.6	8.5236			
1100	0.25330	4254.7	4887.9	8.6804	0.22658	4465.3	5145.1	8.7771	0.19420	4464.4	5144.1	8.7053			
1200	0.27190	4466.3	5146.0	8.8618	0.24207	4682.6	5408.8	8.9502	0.20750	4681.8	5408.0	8.8786			
1300	0.29048	4683.4	5409.5	9.0349											



TABLE A-6

Superheated water (Continued)

T °C	v m <sup>3</sup> /kg	u kJ/kg	h kJ/kg	s kJ/kg-K	v m <sup>3</sup> /kg	u kJ/kg	h kJ/kg	s kJ/kg-K	v m <sup>3</sup> /kg	u kJ/kg	h kJ/kg	s kJ/kg-K
P = 4.0 MPa (250.35°C)				P = 4.5 MPa (257.44°C)				P = 5.0 MPa (263.94°C)				
Sat.	0.04978	2601.7	2800.8	6.0696	0.04406	2599.7	2798.0	6.0198	0.03945	2597.0	2794.2	5.9737
275	0.05461	2668.9	2887.3	6.2312	0.04733	2651.4	2864.4	6.1429	0.04144	2632.3	2839.5	6.0571
300	0.05887	2726.2	2961.7	6.3639	0.05138	2713.0	2944.2	6.2854	0.04535	2699.0	2925.7	6.2111
350	0.06647	2827.4	3093.3	6.5843	0.05842	2818.6	3081.5	6.5153	0.05197	2809.5	3069.3	6.4516
400	0.07343	2920.8	3214.5	6.7714	0.06477	2914.2	3205.7	6.7071	0.05784	2907.5	3196.7	6.6483
450	0.08004	3011.0	3331.2	6.9386	0.07076	3005.8	3324.2	6.8770	0.06332	3000.6	3317.2	6.8210
500	0.08644	3100.3	3446.0	7.0922	0.07652	3096.0	3440.4	7.0323	0.06858	3091.8	3434.7	6.9781
600	0.09886	3279.4	3674.9	7.3706	0.08766	3276.4	3670.9	7.3127	0.07870	3273.3	3666.9	7.2605
700	0.11098	3462.4	3906.3	7.6214	0.09850	3460.0	3903.3	7.5647	0.08852	3457.7	3900.3	7.5136
800	0.12292	3650.6	4142.3	7.8523	0.10916	3648.8	4140.0	7.7962	0.09816	3646.9	4137.7	7.7458
900	0.13476	3844.8	4383.9	8.0675	0.11972	3843.3	4382.1	8.0118	0.10769	3841.8	4380.2	7.9619
1000	0.14653	4045.1	4631.2	8.2698	0.13020	4043.9	4629.8	8.2144	0.11715	4042.6	4628.3	8.1648
1100	0.15824	4251.4	4884.4	8.4612	0.14064	4250.4	4883.2	8.4060	0.12655	4249.3	4882.1	8.3566
1200	0.16992	4463.5	5143.2	8.6430	0.15103	4462.6	5142.2	8.5880	0.13592	4461.6	5141.3	8.5388
1300	0.18157	4680.9	5407.2	8.8164	0.16140	4680.1	5406.5	8.7616	0.14527	4679.3	5405.7	8.7124
P = 6.0 MPa (275.59°C)				P = 7.0 MPa (285.83°C)				P = 8.0 MPa (295.01°C)				
Sat.	0.03245	2589.9	2784.6	5.8902	0.027378	2581.0	2772.6	5.8148	0.023525	2570.5	2758.7	5.7450
300	0.03619	2668.4	2885.6	6.0703	0.029492	2633.5	2839.9	5.9337	0.024279	2592.3	2786.5	5.7937
350	0.04225	2790.4	3043.9	6.3357	0.035262	2770.1	3016.9	6.2305	0.029975	2748.3	2988.1	6.1321
400	0.04742	2893.7	3178.3	6.5432	0.039958	2879.5	3159.2	6.4502	0.034344	2864.6	3139.4	6.3658
450	0.05217	2989.9	3302.9	6.7219	0.044187	2979.0	3288.3	6.6353	0.038194	2967.8	3273.3	6.5579
500	0.05667	3083.1	3423.1	6.8826	0.048157	3074.3	3411.4	6.8000	0.041767	3065.4	3399.5	6.7266
550	0.06102	3175.2	3541.3	7.0308	0.051966	3167.9	3531.6	6.9507	0.045172	3160.5	3521.8	6.8800
600	0.06527	3267.2	3658.8	7.1693	0.055665	3261.0	3650.6	7.0910	0.048463	3254.7	3642.4	7.0221
700	0.07355	3453.0	3894.3	7.4247	0.062850	3448.3	3888.3	7.3487	0.054829	3443.6	3882.2	7.2822
800	0.08165	3643.2	4133.1	7.6582	0.069856	3639.5	4128.5	7.5836	0.061011	3635.7	4123.8	7.5185
900	0.08964	3838.8	4376.6	7.8751	0.076750	3835.7	4373.0	7.8014	0.067082	3832.7	4369.3	7.7372
1000	0.09756	4040.1	4625.4	8.0786	0.083571	4037.5	4622.5	8.0055	0.073079	4035.0	4619.6	7.9419
1100	0.10543	4247.1	4879.7	8.2709	0.090341	4245.0	4877.4	8.1982	0.079025	4242.8	4875.0	8.1350
1200	0.11326	4459.8	5139.4	8.4534	0.097075	4457.9	5137.4	8.3810	0.084934	4456.1	5135.5	8.3181
1300	0.12107	4677.7	5404.1	8.6273	0.103781	4676.1	5402.6	8.5551	0.090817	4674.5	5401.0	8.4925
P = 9.0 MPa (303.35°C)				P = 10.0 MPa (311.00°C)				P = 12.5 MPa (327.81°C)				
Sat.	0.020489	2558.5	2742.9	5.6791	0.018028	2545.2	2725.5	5.6159	0.013496	2505.6	2674.3	5.4638
325	0.023284	2647.6	2857.1	5.8738	0.019877	2611.6	2810.3	5.7596				
350	0.025816	2725.0	2957.3	6.0380	0.022440	2699.6	2924.0	5.9460	0.016138	2624.9	2826.6	5.7130
400	0.029960	2849.2	3118.8	6.2876	0.026436	2833.1	3097.5	6.2141	0.020030	2789.6	3040.0	6.0433
450	0.033524	2956.3	3258.0	6.4872	0.029782	2944.5	3242.4	6.4219	0.023019	2913.7	3201.5	6.2749
500	0.036793	3056.3	3387.4	6.6603	0.032811	3047.0	3375.1	6.5995	0.025630	3023.2	3343.6	6.4651
550	0.039885	3153.0	3512.0	6.8164	0.035655	3145.4	3502.0	6.7585	0.028033	3126.1	3476.5	6.6317
600	0.042861	3248.4	3634.1	6.9605	0.038378	3242.0	3625.8	6.9045	0.030306	3225.8	3604.6	6.7828
650	0.045755	3343.4	3755.2	7.0954	0.041018	3338.0	3748.1	7.0408	0.032491	3324.1	3730.2	6.9227
700	0.048589	3438.8	3876.1	7.2229	0.043597	3434.0	3870.0	7.1693	0.034612	3422.0	3854.6	7.0540
800	0.054132	3632.0	4119.2	7.4606	0.048629	3628.2	4114.5	7.4085	0.038724	3618.8	4102.8	7.2967
900	0.059562	3829.6	4365.7	7.6802	0.053547	3826.5	4362.0	7.6290	0.042720	3818.9	4352.9	7.5195
1000	0.064919	4032.4	4616.7	7.8855	0.058391	4029.9	4613.8	7.8349	0.046641	4023.5	4606.5	7.7269
1100	0.070224	4240.7	4872.7	8.0791	0.063183	4238.5	4870.3	8.0289	0.050510	4233.1	4864.5	7.9220
1200	0.075492	4454.2	5133.6	8.2625	0.067938	4452.4	5131.7	8.2126	0.054342	4447.7	5127.0	8.1065
1300	0.080733	4672.9	5399.5	8.4371	0.072667	4671.3	5398.0	8.3874	0.058147	4667.3	5394.1	8.2819